

Horizontal Systems Specifications

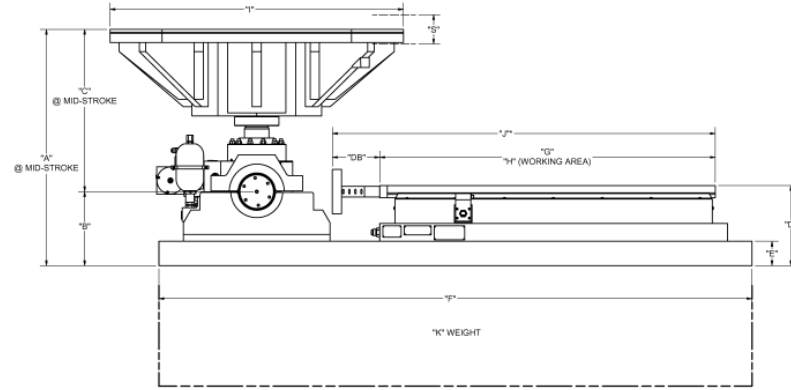

NOTE: All dimensions are approximate.

Physical Dimensions in mm

NOTE: Dimension "C" equal to base plate width

System Model No.	H24-2-62/3.0-140.110	H24-4-64/3.0-350.265	H36-3-62/4.0-140-110	H36-9-64/4.0-350-265	H40-9-62/5.0-140-110	H40-9-64/5.0-350-265	H48-8-64/6.0-350-265	H48-16-64/7.5-350-265	H60-15-86/10.0-350-265	H60-25-810/10.0-350-265
------------------	----------------------	----------------------	----------------------	----------------------	----------------------	----------------------	----------------------	-----------------------	------------------------	-------------------------

A	876	1029	981	1134	981	1134	981	1134	981	1134
B	1858	2189	2163	2494	2264	2595	2467	2798	2772	3103
C	1000	1000	1296	1296	1397	1397	1600	1600	1905	1905
D	333	333	333	333	333	333	333	333	333	333
E	610	610	915	915	1016	1016	1220	1220	1524	1524
Shipping Wt. (Kg)	3070	3870	4525	5315	4945	5920	6870	7180	9300	9650

System Model No. (Table/Actuator/Valve/HPS)	H24-2-62/3.0-140-110	H24-4-64/3.0-350-265	H36-3-62/4.0-140-110	H36-9-64/4.0-350-265	H40-9-62/5.0-140-110	H40-9-64/5.0-350-265	H48-8-64/6.0-350-265	H48-16-64/7.5-350-265	H60-15-86/10.0-350-265	H60-25-810/10.0-350-265
Force	26.7kN	26.7kN	35.6kN	35.6kN	44.4kN	44.4kN	53.3kN	66.7kN	88.9kN	88.9kN
Slip Table Size (mm square)	610	610	900	900	1000	1000	1200	1200	1500	1500
Number of Bearings	2	4	3	9	9	9	8	16	15	25
Pitch Moment kN-m	22	53	52	158	180	180	264	418	475	790
Roll Moment kN-m	13	53	52	158	180	180	211	418	528	790
Yaw Moment kN-m	6	6	12	12	14	14	9	18	24	75
Moving System Mass kg (no load)	81	102	131	172	216	227	220	268	361	406
Displacement pk-pk mm	50	100	50	100	50	100	100	100	150	250
Velocity m/sec	1.1	2.8	0.8	2.0	0.6	1.7	1.4	1.0	0.8	0.8
Acceleration g Bare Table	33.5	26.7	27.6	21.1	21.0	20.0	30.9	20.3	25.2	22.3
Acceleration g with (kg)	8.8(226)	8.3(226)	7.9(226)	7.7(226)	7.0(340)	6.8(340)	7.6(340)	9.8(340)	7.5(680)	7.5(680)
Test Frequency Range Hz	500	500	500	500	500	500	500	500	500	500
Max Frequency Range Hz	250	250	250	250	250	250	250	250	250	250
Max Recommended Payload kg	226	226	226	226	340	340	340	340	680	680
Actuator Type/Piston Area	62/3.0	64/3.0	62/4.0	64/4.0	62/5.0	64/5.0	64/6.0	64/7.5	86/10.0	810/10.0
Valve Combination	V20/140	V20/350	V20/140	V20/350	V20/140	V20/350	V20/350	V20/350	V20/350	V20/350
Recommended Seismic Mass kg	2,268	2,268	2,268	2,268	4,536	4,536	4,536	4,536	6,804	6,804
Hydraulic Power Supply-207 bar	110 l/min	265 l/min	110 l/min	265 l/min	110 l/min	265 l/min	265 l/min	265 l/min	265 l/min	265 l/min
HPS Model No.	HPS-110	HPS-265	HPS-110	HPS-265	HPS-110	HPS-265	HPS-265	HPS-265	HPS-265	HPS-265

1. *If you require a vibration system different to that listed please contact your local *Team* Corporation office or agent for information.
2. 62 Series actuators have a force rating between 26.7 kN and 222 kN
3. 64 Series actuators have a force rating between 26.7 kN and 222 kN
4. 86 Series actuators have a force rating between 88.96 kN and 195.72 kN
5. 810 Series actuators have a force rating between 88.96 kN and 195.72 kN
6. Use this sheet in conjunction with Vertical Systems Specification Sheet