



*The Leaders in High Performance Hydraulics*

---

**TECHNICAL ANALYSIS**  
**OF**  
**TEAM T-FILM**  
**SLIP TABLE**

**ABSTRACT**

The T-Film slip table has been designed to lower the cost and improve the quality of vibration testing. This paper shows that the critical slip table parameter for determining performance is the stiffness of the bearing. It is then shown that the T-Film bearing is more than 50 times stiffer than our standard journal bearing. This results in deflections and cross axis accelerations that are 1/50<sup>th</sup> those of our (or anyone else's) standard journal bearing slip table.

Copyright© 1989 by TEAM Corporation. No part of this "Technical Analysis of Team T-Film Slip Table" may be reproduced in whole or in part or excerpted, in any manner without prior approval, in writing, from TEAM Corporation

## **1 INTRODUCTION**

About 10 years ago, Team introduced a new slip table that promised to provide a breakthrough in slip table performance. The T-Film Table has met and exceeded 100's of customer's needs and expectations. This paper presents the technical concepts and numerical data to explain the significantly improved performance.

The question that comes immediately to mind is: "What constitutes slip table performance?" The answer is that slip table performance is the ability to support a load, and restrain it to move in one horizontal axis only, so that pure single axis motion is achieved.

Before elaborating on that however, the basic slip table function and what an ideal slip table would be needs discussion. A quick review of the dynamics of the slip table and the load package is provided before going in depth into the design and analysis of the T-Film bearing. This is then contrasted with the standard journal bearing table that we previously produced for years. It will be easy to see that the T-Film table offers an order of magnitude improvement in "performance".

## **2 SLIP TABLE BASICS**

A slip table is a load carrying bearing used, in conjunction with a shaker, to support a load and input a vibratory motion to the base of the load. The load will generate overturning moments and often yaw moments in response to the vibratory motion at its base. The slip table's job is to keep the load moving in the desired single axis motion, and resist the overturning or yawing moments. See Figure 1 for the classic slip table – shaker configuration.

The term "slip table" is used to refer to a specific design of bearing in which a "slip plate" (which is attached to the shaker) rides on a thin film of oil on top of a reaction base, often a granite block. "Slip table" is used to refer to the complete assembly and "slip plate" refers to the moving, load-carrying plate.

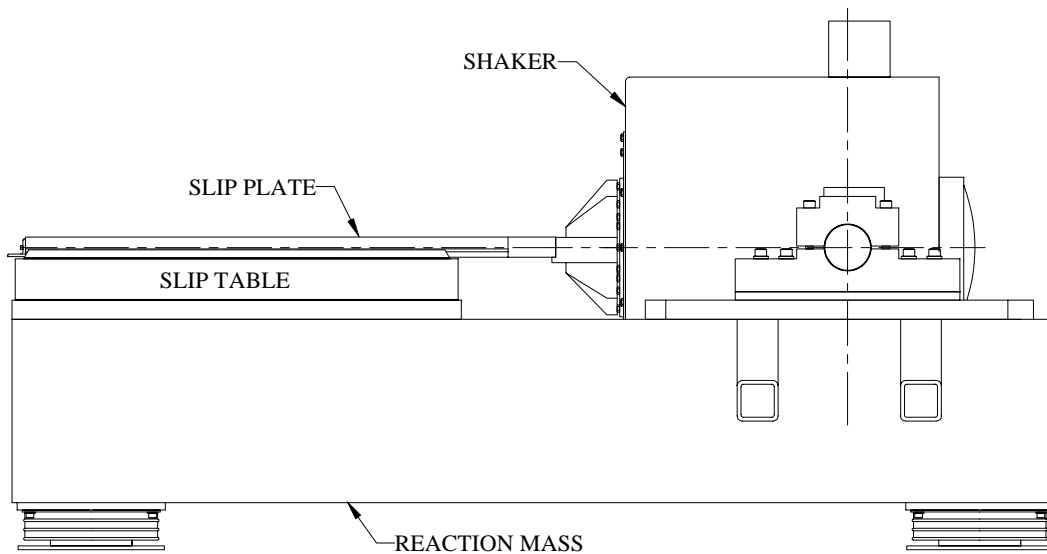

Figure 1 Typical Shaker and Slip Table System

### **3 THE ALL-IMPORTANT REACTION MASS**

The reaction base plays an important part in the dynamics of the system since the slip plate uses the mass and rotational inertia of the base to resist overturning moments and cross axis motions of the load. **The key to slip table performance is its ability to couple the moments and cross axis forces into the reaction base.** When the slip plate is well coupled to the reaction mass, the overturning moments generated by the load are reacted by the sizable reaction inertia, and very little motion results. If the slip plate is not very well connected to the reaction base, the load is free to rotate about its center of gravity, and large cross axis motions result.

### **4 THE IDEAL SLIP TABLE**

The ideal slip table would have a number of attributes. Foremost, it would be frictionless in the direction of travel, and would be infinitely stiff in all other directions to couple to the reaction mass effectively. In other words, it would have a single degree of freedom. It would have a massless slip plate so that all the shaker force would be available to shake the test specimen. It would have uniform motion on the slip plate at all frequencies, (uniform dynamic response) so that all packages, or all parts of a large test item, would be subjected to the same vibration input. The slip table would carry large packages, and would have very high moment restraint capacity so the slip plate does not “slap”. The slip table would allow a package, or more precisely a threaded insert, to be placed anywhere on it. The complete slip table would be indestructible, inexpensive and have an infinite life.

How do current slip table designs compare to this “ideal”? There are several configurations of slip tables available, most notably the simple oil film/granite block table and the hydrostatic journal bearing/oil film/granite block table.

The oil film/granite block table is usually called an “oil film” table, and consists of a smooth, flat piece of granite and a magnesium or aluminum slip plate, separated by a film of oil or grease. The oil is often pumped into the plate/granite interface so that it can be used continuously. The system is simple and inexpensive, though it has very little cross axis motion restraint, low load capacity and is not suitable for large packages or high levels of vibration input. At high levels, or with packages with a high center of gravity, the load tends to rotate about its center of gravity, which causes the slip plate to lift off the granite and slap back down, creating shocks on the test article and splattering oil.

The hydrostatic journal bearing table is of similar construction, except that holes are cut into the granite block and hydrostatic journal bearings or Team preloaded “V” bearings are installed. The bearings are mounted to the base plate and the slip plate is attached to the moving element of the bearing. The bearings hold the slip plate down to resist the “pitch” motion and provide the lateral restraint to prevent “yaw” motion of the slip plate. These tables can provide very significant cross axis motion restraint, and can carry large, heavy loads. They require a hydraulic power supply of 3000-psi pressure, which is expensive and adds a lot of heat to the plate. The theoretical load capacity increases with the number of bearings, but the real cross axis motion often increases when more bearings are added because so much of the granite is cut out to make room for the bearings. In addition, the slip plate has oil passages machined in it to feed the bearings, so one cannot put an insert in wherever one might need. A typical hydrostatic journal bearing table is shown in Figure 2.

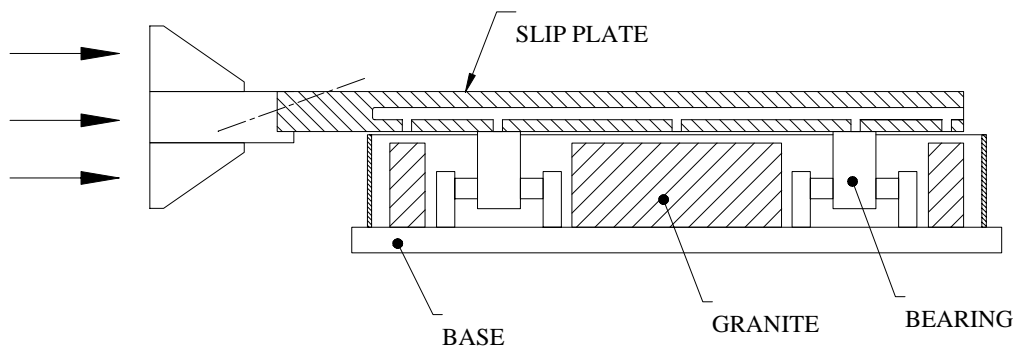

Figure 2 Cut-Away View of Journal Bearing Slip Table

## 5 SLIP TABLE DYNAMICS

Two important and related analyses must be made for any slip table system. The first is the calculation of the loads and forces that will be generated by the shaker system. The other is the load capacity of the slip table system, and the deflections and motions that result from the generated loads.

The loads that are generated are most easily understood with some simplifying assumptions. The load mass is assumed to be a rigid body and dynamically “dead” (non-resonant). The slip plate is assumed to behave as a rigid body, infinitely stiff, so that it doesn’t bend, and so that it moves uniformly across its length and width. These are not valid at high frequencies, but are approximately true at some low frequency. Figure 3a is a drawing of the forces and moments acting on the load and slip table as a result of the shaker force.

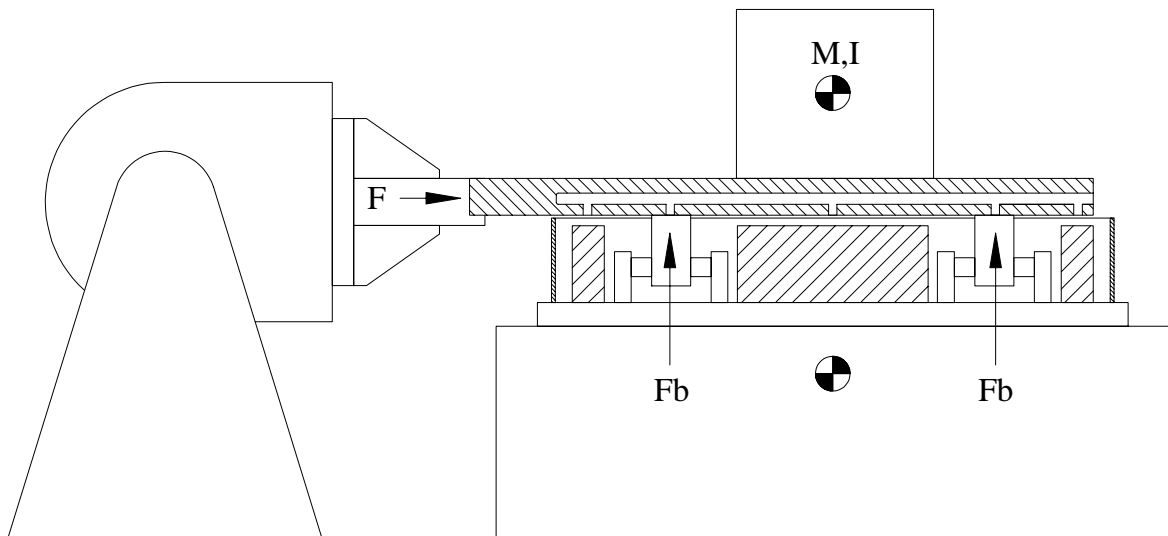

Figure 3a Forces Acting on Slip Plate

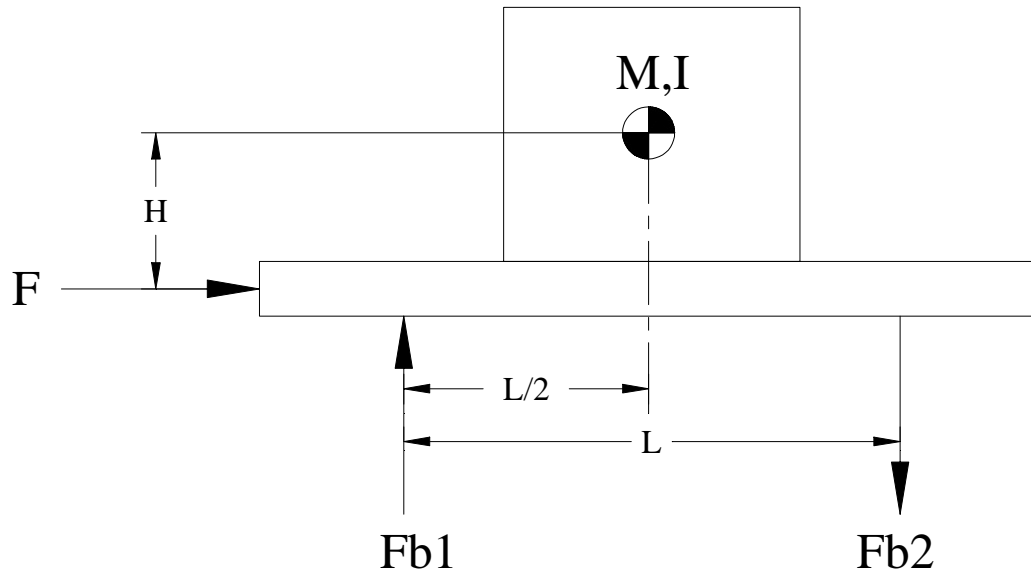

Figure 3b Free Body Diagram of Forces Acting on Slip Plate

The free body diagram of the load, Figure 3b, shows that for the summation of forces in the direction of the shaker force, Newton's law holds and  $F = ma$ .

It is desired that the load not move in the vertical or lateral cross axis directions, so the equations that apply are the static equations that the sum of forces and moments equal zero. Thus, to prevent any "pitch" motion, the bearing forces must create an equal and opposite moment to that generated by the shaker force. The load tends to rotate about its center of gravity, so the moments are summed about the CG. The inertial force, equal to  $-F$ , acts at the CG. Thus, summing moments about the CG gives:

$$F_b L = Fh$$

Where:  $F_b$  is the force generated by each bearing  
 $L$  is the distance between the bearings  
 $F$  is the shaker force  
 $H$  is the height of the center of gravity

Notice that the mass of the load does not come into play. Only its height above the slip plate and the shaker force affect the moment generated by the load.

Now, the important point to acknowledge is that the bearings act like very stiff springs. The relationship between the force generated by the bearing and its deflection is of the form:

$$F_b = kx$$

Where:  $F_b$  is the bearing force  
 $k$  is the spring constant  
 $x$  is the spring deflection

Thus, to generate the force to resist the pitch moment calculated earlier, **the bearing must deflect**. When the bearing deflects, a cross axis motion is introduced that shows up as cross axis acceleration on the test specimen. To minimize the cross axis motion, the bearing must be very stiff. The higher the stiffness, the lower the cross axis motion that results at **any** force level.

An example illustrates the point. Assume you have a 20,000-lbf shaker, a 48-inch journal bearing slip table with 2 bearings and a load whose CG is 24 inches above the slip plate.

The moment balance equation gives:

$$F_b L = Fh$$

so

$$F_b = F \left( \frac{h}{L} \right)$$

For this system, the bearings are about 40" apart, so:

$$F_b = 20,000 \left( \frac{24}{40} \right)$$

$$F_b = 12,000 \text{ lbf}$$

How much must the bearing deflect to generate 12,000 lb force? A standard journal bearing will be shown to have a stiffness of about 4,000,000 lb/in so the deflection required would be:

$$x = \frac{F}{k}$$

$$x = \frac{12,000}{4,000,000}$$

$$x = .003\text{inches}$$

If your load weighed 2000 lb and the mass were concentrated at the CG for a low rotational inertia, then the 20,000 lb force input would generate a longitudinal acceleration of about 10 Gs. Looking up the acceleration resulting from the previously determined .003 inch displacement (.006 inch DA) on a vibration calculator shows the cross axis acceleration level that would be experienced by the test article. At 300 Hz, the resulting acceleration would be about 27 Gs, or 270% of the input. At 500 Hz, it is more than 75 Gs, or 750% of the input.

The T-Film table will be shown to have a **stiffness of  $2.1 \times 10^8$  lb/in**. This results in a deflection, under the same conditions as used above, of only 60 microinches, with a corresponding acceleration of only 0.5 Gs at 300 Hz (5% cross axis) and 1.5 Gs at 500 Hz (15% cross axis). This is a much more acceptable cross axis acceleration level.

Note, however, that since the load mass is experiencing significant rotational acceleration, the original equation for static equilibrium is not valid, and the proper equation would be the equation of motion for a rotational system, that is:

$$T = I\alpha$$

Where:  $T$  = sum of all torques acting on the body

$I$  = rotational inertia of the body

$\alpha$  = angular acceleration

For packages with small rotational inertias, the angular accelerations will be very high, and the conclusions drawn from the static analysis are reasonable.

This example is based on ideal conditions. All loads were assumed to go directly into the bearing, and the bearing was assumed to be the only thing that deflected. In reality, the load cannot be tied directly into the bearings, the slip plate deflects, the load package deflects and resonances appear that all conspire to make cross axis control more difficult.

The ideal slip plate would have lots of very stiff bearings so that the load could be attached to them as directly as possible.

## **6 T-FILM TABLE DESIGN – APPROACHING THE IDEAL**

Team approached a new table design with two goals in mind. First was to create a table whose performance would surpass that of a standard journal bearing table by such a margin that it would be impossible to refute. Second, it had to be competitively priced.

In the T-Film table, these two goals have been realized.

The T-Film table is shown in an exploded view in Figure 4. It is comprised of a number of precision machined, one-foot square, bearing elements. Each bearing consists of a hydrostatic “T beam” bearing element and a hydrostatic oil film surface for the slip plate to ride upon.

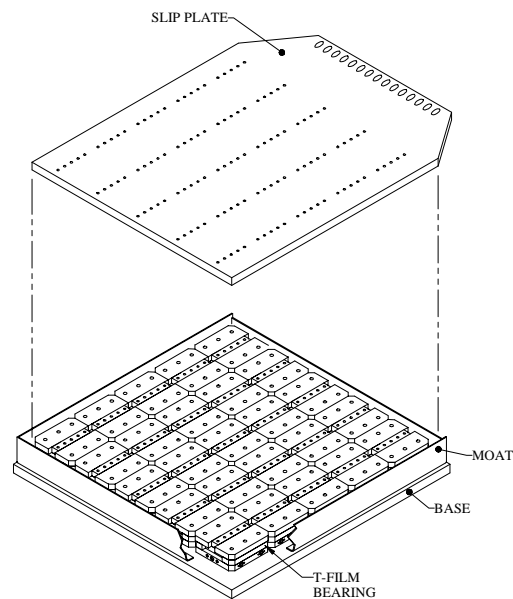

Figure 4 T-Film Table Assembly

The bearing elements are placed side by side in an oil moat, the number of bearings being dictated by the size of the slip table desired. The larger the table desired, the more bearings are supplied.

The bearings operate at 600-psi. This allows the use of a simple pump, similar to that used for a standard “oil film” table. Heat build-up is not a problem, and the table needs no additional expensive high-pressure hydraulic power supply with oil cooler.

The design of each bearing element is such that the net oil film area (which is shown later to be one very important criterion for stiffness) is a full 127% of the nominal slip plate area. In addition, there is virtually no part of the installed slip plate that is not supported on an oil film.

The bearings are everywhere. There are only 12 inches between the rows of bearings, so the test specimen can be bolted directly down onto the bearings. The rows of bearings are continuous down the length of the table.

Figure 5 shows the load path of a force applied to a T-Film bearing. Figure 6 shows it applied to a standard journal bearing. In the T-Film bearing, **the load is transmitted straight down into the base plate. The load path cannot be more direct.** In the journal bearing, the load must pass through the shaft, which introduces a bending load in the shaft and results in significant deflections.

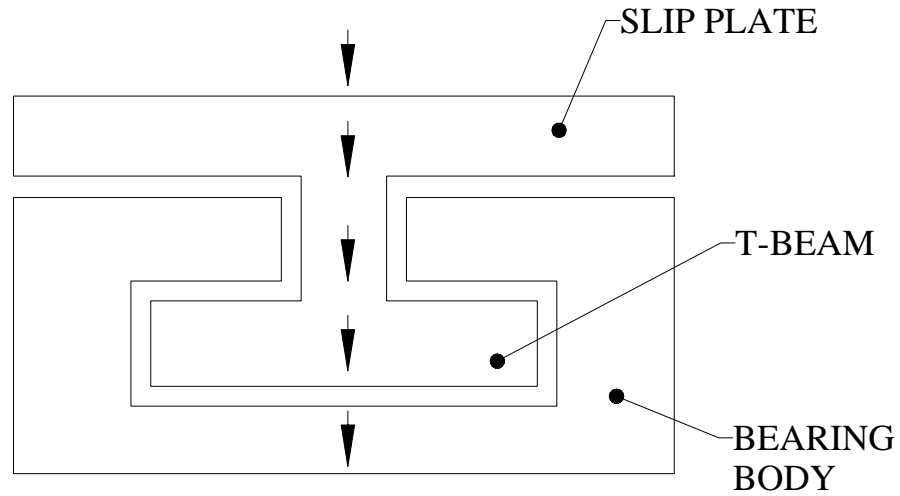

Figure 5 Load Path through a T-Film Bearing

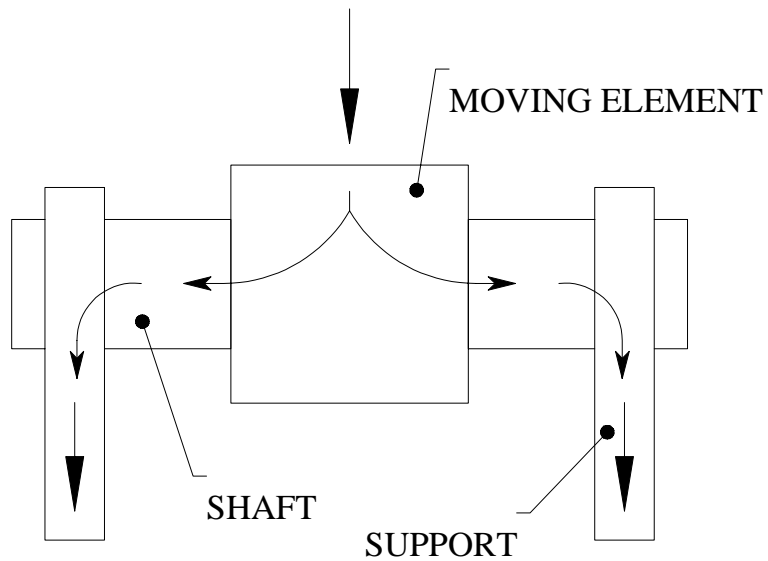

Figure 6 Load Path through a Journal Bearing

The T-Film Table features:

- ◆ Extraordinary stiffness – for the best cross axis motion control and the best, most accurate test
- ◆ Extraordinary load capacity – for heavy or dense packages
- ◆ Many bearings – the test article can be bolted down very close to many bearings
- ◆ Great oil film area – for stiffness and damping and cross axis motion control
- ◆ Low pressure oil system – for low maintenance, low cost, ultimate simplicity
- ◆ No oil porting through the plate gives these benefits:
  - The plate can be inexpensive
  - The plate can be thick or thin
  - The plate can have inserts placed virtually anywhere
  - The plate can be made of aluminum, magnesium or other exotic material
  - Dedicated fixtures could be made to bolt directly to the bearings with no intermediate plate required

## **7 STIFFNESS ANALYSIS OF T-FILM BEARING**

The stiffness of the bearing has been shown to be the critical parameter of slip table performance. The following section will develop the equations and calculate the stiffness of the T-Film bearing. In the next section, the stiffness of the standard journal bearing is calculated.

Figure 7a shows the cross section of a T-Film bearing. Figure 7b is the spring model used to assess the overall stiffness of the bearing. Breaking the bearing down into elements whose spring rates are easily calculated develops the model. The individual spring rates are then added together in parallel and series, as appropriate, to get the overall spring rate from the point of application of the load to the base.

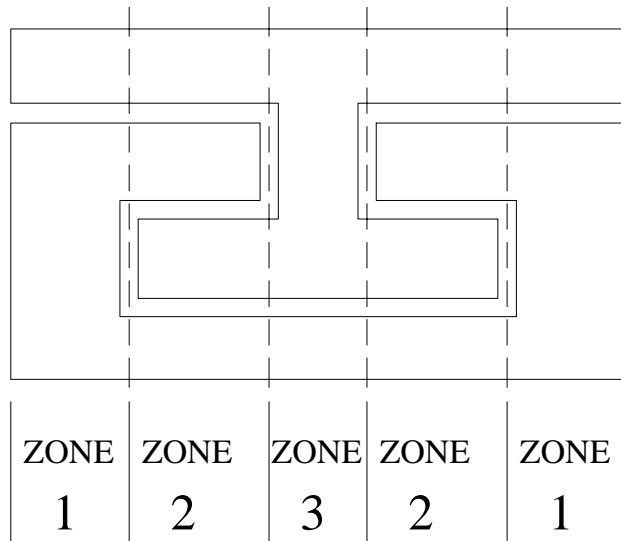

Figure 7a Stiffness Zones of T-Film Bearing Stiffness Model

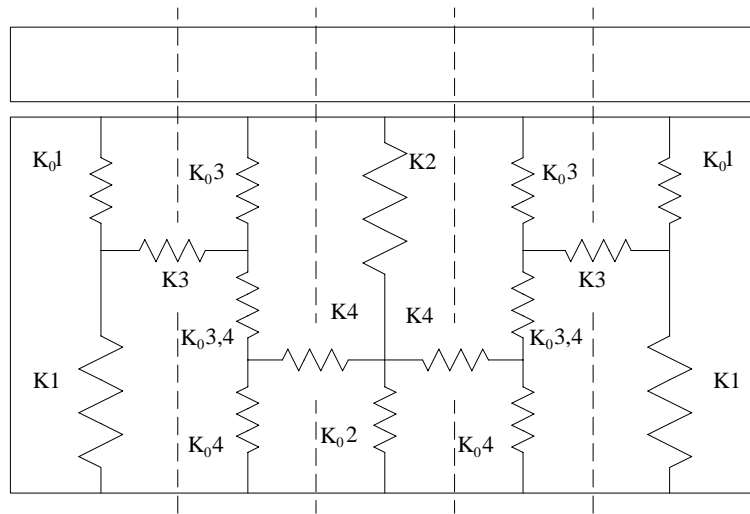

Figure 7b Spring Model of T-Film Bearing

The assigned springs are defined as follows:

- $K_0$  = spring constant of the oil film in tension and compression
- $K_1$  = spring constant of the bearing body in Zone 1, solid material in tension and compression
- $K_2$  = spring constant of the center section of the “T beam” in Zone 3, material in tension and compression

- K3 = spring constant of the cantilever section of the bearing body in Zone 2, material in bending, shear and compression
- K4 = spring constant of the cantilever section of the “T beam”, Zones 2 and 3, material in bending, shear and compression.

Spring rate calculations:

The spring rate of a material undergoing tensile and compressive loading is a function of the geometry and the material’s modulus of elasticity.

For simple longitudinal tension and compression of a solid member (as opposed to bending or torsion or shear), the stiffness is given by:

$$K = A \left( \frac{E}{L} \right)$$

Where:  $K$  = spring rate (lb/in)  
 $A$  = cross sectional area (in<sup>2</sup>)  
 $E$  = Young’s Modulus of Material (lb/ in<sup>2</sup>)  
 $L$  = length (in)

For an oil film, the stiffness equation takes on a very similar form, where instead of the Young’s Modulus being the measure of the material stiffness, the Bulk Modulus is the measure used.

The oil film stiffness is given by the equation:

$$K = B \left( \frac{A^2}{V} \right)$$

Where:  $K$  = spring rate (lb/in)  
 $B$  = Bulk Modulus of oil = 200,000-psi (lb/ in<sup>2</sup>)  
 $A$  = load bearing area (in<sup>2</sup>)  
 $V$  = volume of oil in the oil film (in<sup>3</sup>)

Note that the volume in the oil film is simply the area times the thickness, so the stiffness equation reduces to:

$$K = B \left( \frac{A}{t} \right)$$

Where  $t$  is the oil film thickness

This is the same form as the equation for a solid.

The bearing also has, in Zone 2, members K3 and K4 that are loaded in bending. The stiffness of these members is more difficult to analyze since the oil film loading on the beams is complicated and is itself a function of the beam deflection. The beam deflection is actually a combination of shear, bending and compressive deflection, and the analysis of those members is beyond the scope of this work, so their contribution to bearing stiffness is omitted. The stiffness of the complete bearing is shown to be much greater than a journal bearing even without the contribution of members K3 and K4. It is clear that these members add to the total bearing stiffness, so the error due to their omission in the overall stiffness calculation is that the calculated stiffness will be on the low side.

Using the stiffness equations presented, the bearing stiffness is calculated as follows:

The equivalent stiffness for K1 is:

$$K1 = A \left( \frac{E}{L} \right)$$

$$A = 3 \times 12 = 36 \text{ in}^2$$

$$E = 10 \times 10^6 \text{ lb/in}^2$$

$$L = 4.2 \text{ in}$$

$$K1 = 85.7 \times 10^6$$

The equivalent stiffness for K<sub>0</sub>1 is:

$$K_{0,1} = B \left( \frac{A}{t} \right)$$

$$B = 200,000 \text{ lb/in}^2$$

$$A = 36 \text{ in}^2$$

$$t = 0.002 \text{ in}$$

$$K_{0,1} = 3.6 \times 10^9$$

The equivalent stiffness for K2 is:

$$K2 = A \left( \frac{E}{L} \right)$$

$$A = 19 \text{ in}^2$$

$$E = 10 \times 10^6 \text{ lb/in}^2$$

$$L = 4.2 \text{ in}$$

$$K_2 = 45 \times 10^6$$

The equivalent stiffness for  $K_{o2}$  is:

$$K_{o2} = B \left( \frac{A}{t} \right)$$

$$B = 200,000 \text{ lb/in}^2$$

$$A = 19 \text{ in}^2$$

$$t = 0.002 \text{ in}$$

$$K_{o2} = 1.9 \times 10^9$$

The total bearing stiffness is the parallel combination of stiffness zones 1,2 and 3. The stiffness in each zone is the combination of the material and oil films in series (Note: springs are added in series and parallel as capacitors are in electrical systems).

$$K_{TOTAL} = \left[ \frac{2}{\left( \frac{1}{K_{o1}} + \frac{1}{K1} \right)} \right] + \left[ \frac{1}{\left( \frac{1}{K_{o2}} + \frac{1}{K2} \right)} \right]$$

$$K_{TOTAL} = 2.11 \times 10^8$$

The total vertical stiffness of the T-Film bearing is essentially that of a solid block of aluminum of the same area and height.

## **8 JOURNAL BEARING STIFFNESS ANALYSIS**

The journal bearing construction and the equivalent spring model are shown in Figures 8a and 8b respectively. The equations for the oil film stiffness and for the material loaded in tension and compression, springs  $K_{o1}$  and  $K$  support respectively, have been presented earlier.

The journal bearing in a Team slip table is mounted in a hole cut out of the granite. The area of that hole ranges from 83 to 113 square inches, and the slip plate is supported only by the bearing in that area. Each T-Film bearing is analyzed over a total surface area of 91 square inches, approximately the size of the journal bearing cutout. Thus, it is reasonable to omit any stiffness contribution from the granite-oil film in the journal bearing calculation.

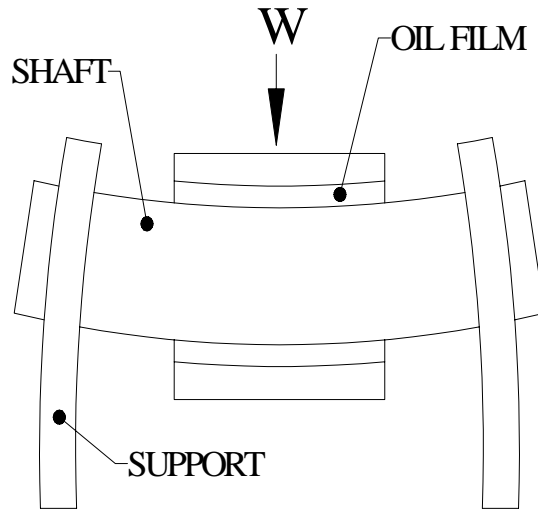

Figure 8a Journal Bearing Stiffness Model

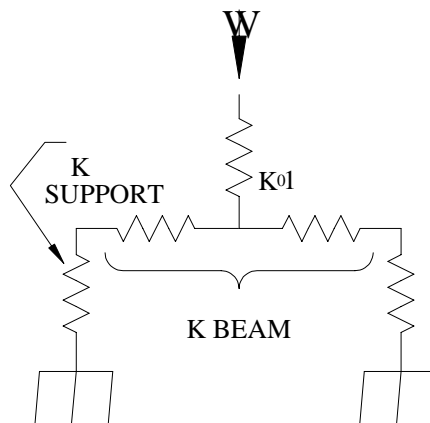

Figure 8b Spring Model of Journal Bearing

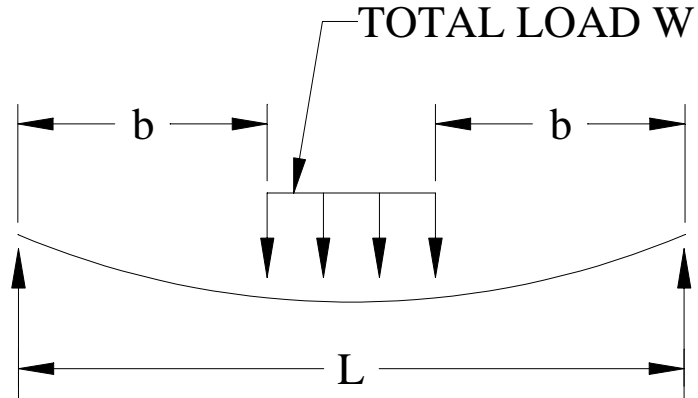

Figure 9 Beam Loading Conditions for Deflection Analysis

For a beam, simply supported at the ends and with a load spread over some distance in the center, as shown in Figure 9, the deflection equation is:

$$d = \left[ \frac{WL^3}{384(E)(I)(1-2\alpha)} \right] (5 - 24\alpha^2 + 16\alpha^4)$$

- Where:  $d$  = the deflection  
 $W$  = the load  
 $L$  = the beam length  
 $I$  = the moment of inertia  
 $E$  = the modulus of elasticity  
 $\alpha = b/L$   
 $b$  = distance from end of beam to load

Stiffness is the ratio of applied load to deflection, so the stiffness is easily derived from the deflection equation.

$$K_{BEAM} = \left[ \frac{E(I)384(1-2\alpha)}{L^3(5-24\alpha^2+16\alpha^4)} \right]$$

The journal bearing shaft is 3.0 inch diameter aluminum, so:

$$\begin{aligned} E &= 10 \times 10^6 \\ I &= 4 \text{ (in}^4\text{)} \\ L &= 7.5 \text{ (in)} \\ \alpha &= 0.367 \\ K_{BEAM} &= 4.7 \times 10^6 \text{ (lb/in)} \end{aligned}$$

The stiffness of the oil film is:

$$K_{o1} = 200,000 \left( \frac{10}{0.002} \right) = 1 \times 10^9$$

The stiffness of the shaft supports is:

$$K_{SUPPORT} = 2A \left( \frac{E}{L} \right) = 32.5 \times 10^6$$

The total bearing stiffness is calculated as follows:

$$K_{TOTAL} = \left[ \frac{1}{\frac{1}{K_{o1}} + \frac{1}{K_{BEAM}} + \frac{1}{K_{SUPPORT}}} \right]$$

$$K_{TOTAL} = 4.09 \times 10^6$$

Thus, **the stiffness ratio of the T-Film bearing to our standard journal bearing is approximately 50:1**. This means that the same bearing restraining forces will be generated with 1/50<sup>th</sup> the deflection, and therefore, 1/50<sup>th</sup> the cross axis acceleration for a single bearing. Recall that the T-Film Table uses many bearings so the improvement is even greater.

## 9 CONCLUSION

It has been shown that the stiffness of the connection of the slip plate to the reaction mass is critical to the performance of a slip table. The bearings provide this stiffness and the T-Film bearing is 50 times stiffer than our standard journal bearing. Add this to the fact that the T-Film Table maximizes the number of bearings, allowing the load to be mounted either directly on or very close to a bearing element, and it is clear that the T-Film Table is a breakthrough in vibration table design.